

510MM X 510MM MILD STEEL BAR GRATING FROM 20MM MIN BARS WITH 12MM MAX SPACES.

PAVING SLAB

OUTLET LEVEL

STRAINING BASKET
(refer note 1 below)

100 MIN. CONCRETE WALLS AND BASE WITH SMOOTH INTERNAL FINISH

100MM DIAMETER OUTLET

100 x 88.5 CAST IRON BEND WITH LARGE INSPECTION OPENING

600 MIN

100 MIN

SECTION A - A

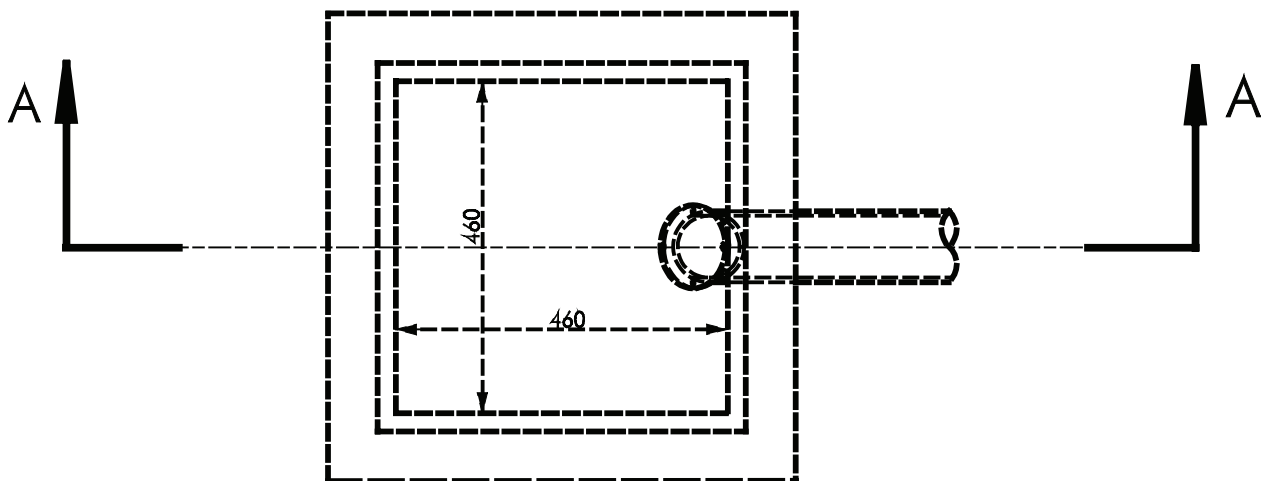

PLAN

(BUCKET AND GRATING REMOVED)

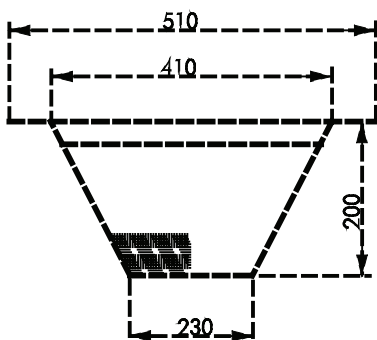

SECTION B-B

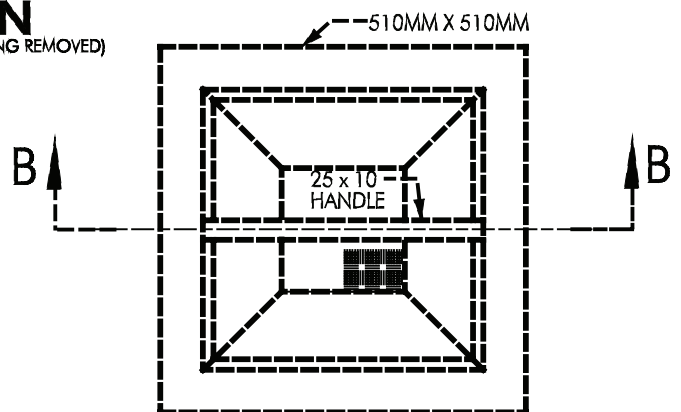

BASKET PLAN

Notes:

1. Basket to be constructed of 2.5mm (min dia.) Wire woven to give 7mm aperture widths on a 32 x 32 x 3mm angle iron frame with mitred corners. Top to be welded to angle iron frame. Basket to be galvanised after manufacture. Alternatively, the basket may be constructed from 3mm thick (min) mild steel plate with 6mm dia. Holes at 12mm centres over the entire area of the basket. The basket to be galvanised after manufacture.
2. The straining pit must be constructed, installed and connected in accordance with the relevant plumbing regulations.



20 Corporate Drive
Heatherton, Vic 3202

Straining Pit

APPROVED:
JEFF WINEBERG

DRAWN BY:
MACINTOLOGY

SCALE:
N.T.S.

DRAWING NO:

AM 10

DATE:
01 / 07 / 2007