

SECTION A - A

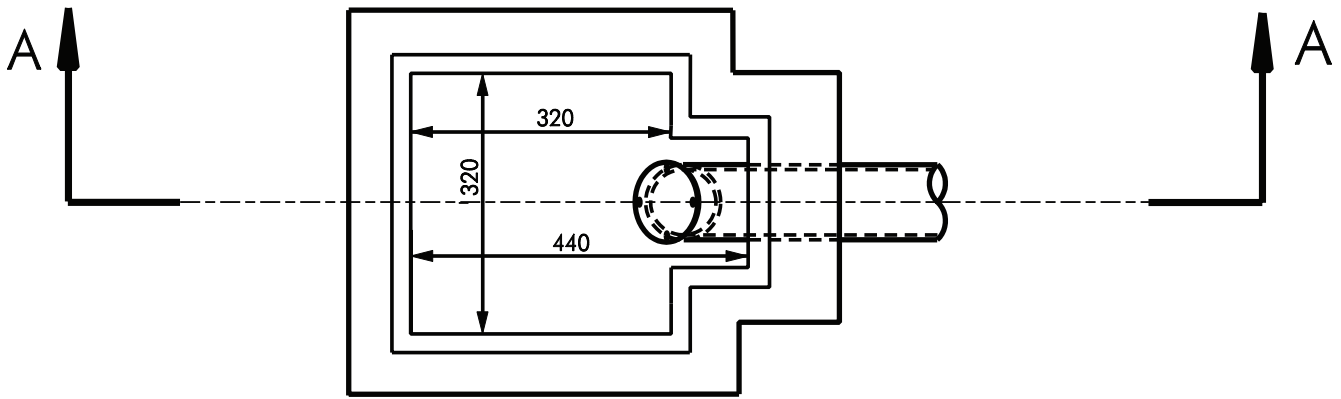

PLAN

(BUCKET AND GRATING REMOVED)

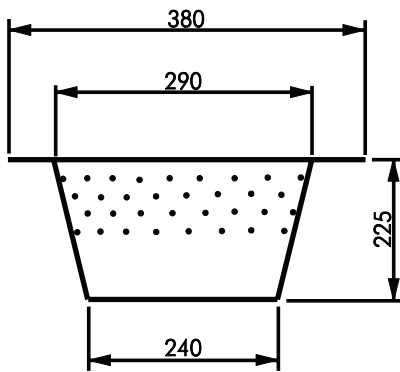

SECTION B-B

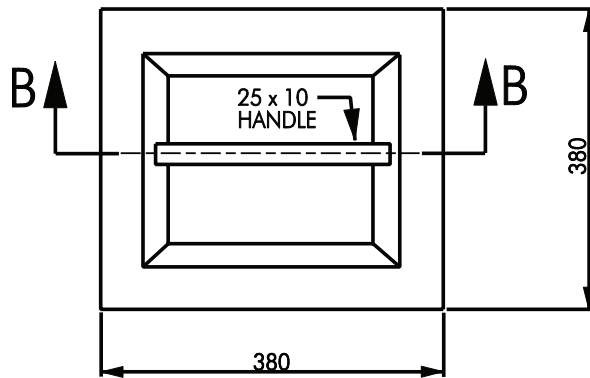

PLAN

Notes:

1. Bucket to be constructed of 3mm minimum thick mild steel plate with 5 rows of 10mm diameter holes at 25mm centres.
2. Bucket to be galvanised after fabrication.
3. The silt pit must be constructed, installed and connected in accordance with the relevant plumbing regulations.



20 Corporate Drive
Heatherton, Vic 3202

Silt Pit

APPROVED:
JEFF WINEBERG

DRAWN BY:
MACINTOLOGY

SCALE:
N.T.S.

DRAWING NO:

AM 12

DATE:
01 / 07 / 2007