

GENERAL INSTALLATION NOTES

- THE PROPERTY SERVICE PIPE & WATER METER ASSEMBLY MUST BE INSTALLED BY AN APPROPRIATELY QUALIFIED PERSON.
- COPPER RISERS ARE NOT TO BE SURROUNDED BY CONCRETE.
- ALL VALVES AND FITTINGS MUST BE WATERMARK APPROVED.
- METER ASSEMBLY PIPE WORK AND FITTINGS SHALL BE IN COPPER AND COPPER ALLOY FITTINGS.
- METER ASSEMBLY INSTALLATIONS SHALL COMPLY WITH AS/NZS 3500.1:2003 & RELEVANT WATER BUSINESS REQUIREMENTS.
- THE METER ASSEMBLY SHALL BE HORIZONTAL. IF AN ALTERNATIVE ARRANGEMENT IS NECESSARY, PRIOR CONSENT IS REQUIRED.
- FOR 32mm+ SERVICES, A DIRT BOX IS REQUIRED WITH ALL METERS, WITH THE EXCEPTION OF MAGNETIC FLOW METERS.
- CONTAINMENT BACKFLOW PREVENTION IS REQUIRED ON ALL NEW GENERAL WATER CONNECTIONS.
 - (a) FOR LOW HAZARD PROPERTIES A NON TESTABLE BACKFLOW PREVENTION DEVICE SHALL BE FITTED.
 - (b) FOR HIGH / MEDIUM HAZARD PROPERTIES A TESTABLE BACKFLOW PREVENTION DEVICE SHALL BE FITTED.
- WHERE TESTABLE BACKFLOW PREVENTION DEVICES ARE REQUIRED, THE ISOLATING VALVE SHOWN IMMEDIATELY UPSTREAM OF THE LINE STRAINER & IMMEDIATELY DOWNSTREAM OF THE DEVICE, MUST HAVE RESILIENT SEALING.
- THE OUTLET THREAD OF THE TESTING FERRULE MUST BE CAPPED.
- FOR FIRE SERVICES AN APPROVED SINGLE SPRING LOADED DETECTOR CHECK VALVE MUST BE INSTALLED.
- INLET ISOLATING VALVE (2) MAY ALTERNATIVELY BE LOCATED BELOW GROUND WITH A COVER TO SURFACE.
- PRIOR SPECIFIC CONSENT IS REQUIRED FROM THE RELEVANT FIRE AUTHORITY TO INCORPORATE INLINE WATER METERS FOR FIRE SERVICES.
- GENERAL WATER METER ARRANGEMENTS GREATER THAN 100mm TO BE ASSESSED ON A CASE BY CASE BASIS.
- AN ISOLATING VALVE SHALL BE INSTALLED IN AN ACCESSIBLE POSITION OUTSIDE THE BUILDING i.e. SHOP.
- BACKFLOW PREVENTION DEVICES INSTALLED TO BE READILY REMOVABLE FOR MAINTENANCE/REPLACEMENT.
- WHERE THE INSTALLATION IS FOR CLASS 'A' RECYCLED WATER, THE INSTALLATIONS MUST COMPLY WITH THE RELEVANT STANDARDS. WHERE VALVING/PIPEWORK CONFIGURATIONS VARY FROM THE ARRANGEMENTS SHOWN IN THESE DIAGRAMS (1-17), CONSULTATION WITH THE RELEVANT WATER BUSINESS IS REQUIRED.

SCHEDULE OF ITEMS	
ITEM NO.	DESCRIPTION
1	TAPPING BAND
1A	TEE
2	FERRULE/BALL/GATE/SLUICE VALVE
2A	DIVIDE VALVE
3	ALL POLYETHYLENE PIPE & FITTINGS MUST BE WATERMARK APPROVED PIPE TO BE Pn16 MINIMUM
	TAPPING HOLE DIMENSIONS AS PER TAPPING GUIDELINES

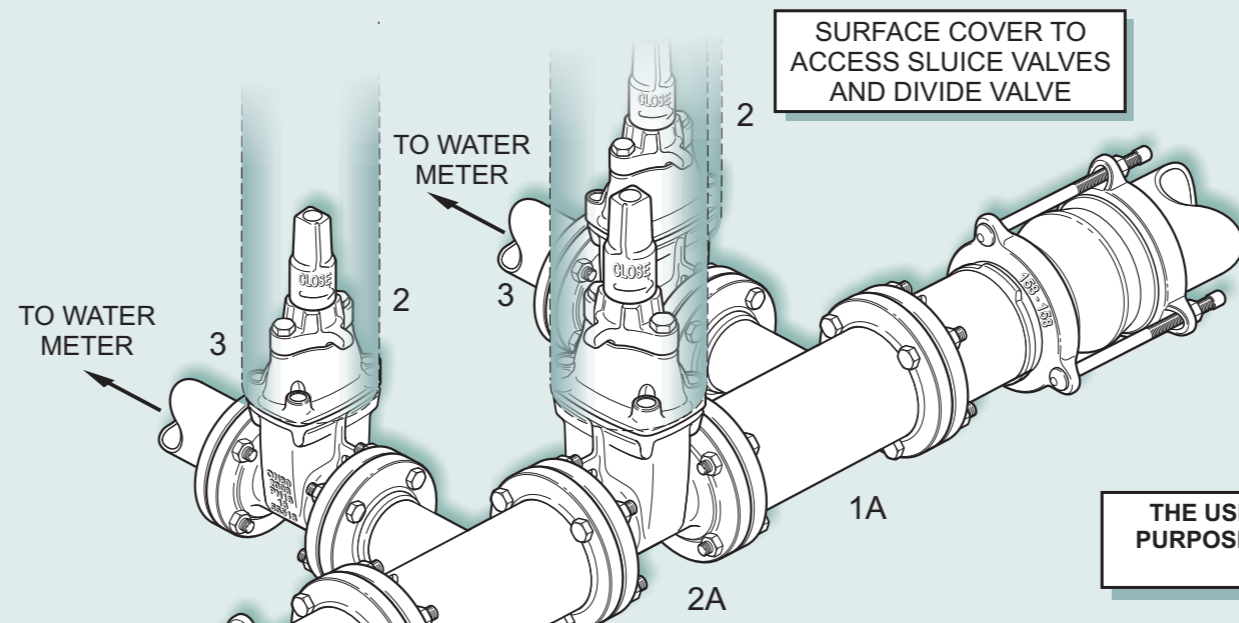

THE USE OF CLASS 'A' RECYCLED WATER FOR FIRE FIGHTING PURPOSES MAY BE CONSIDERED SUBJECT TO SPECIFIC WATER BUSINESS REQUIREMENTS.

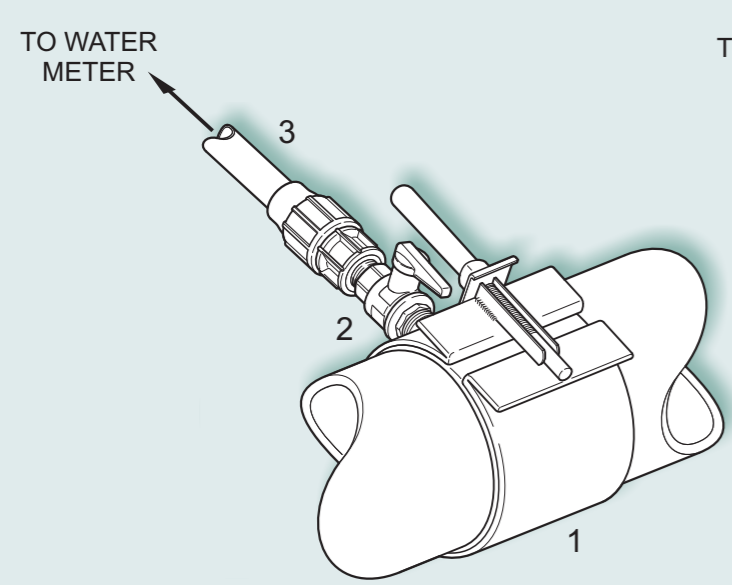
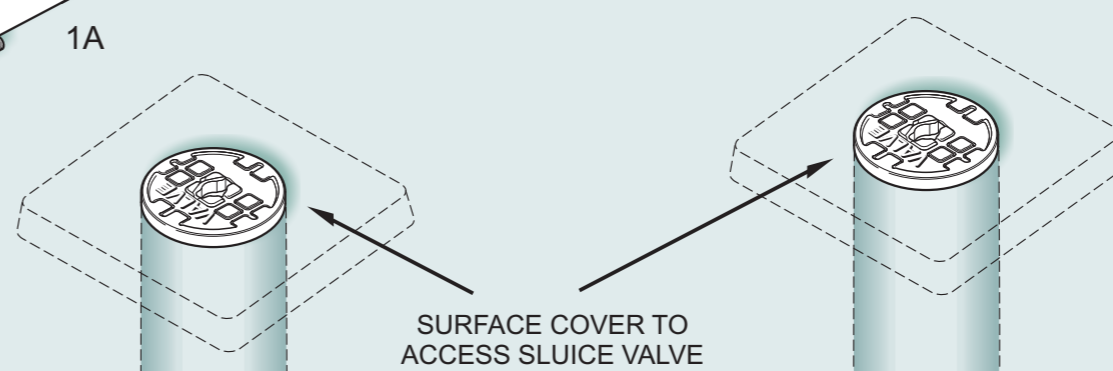

TAPPING UNDER PRESSURE UP TO 50mm (BALL VALVE)

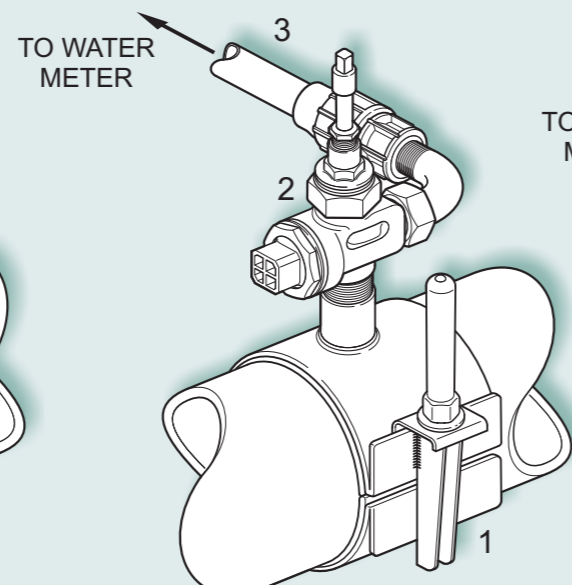

TAPPING UNDER PRESSURE UP TO 50mm (FERRULE & BEND)

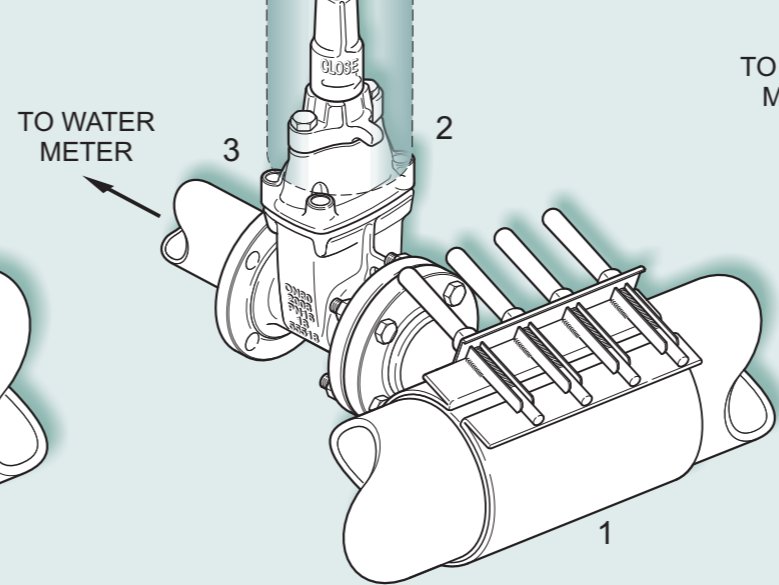

TAPPING UNDER PRESSURE GREATER THAN 50mm

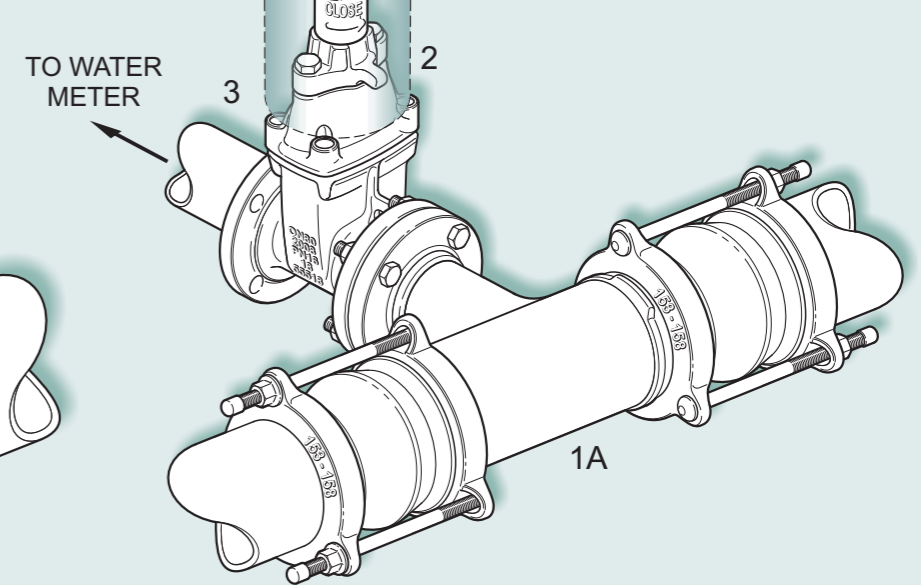

TEE INSERTION GREATER THAN 50mm (MAIN SHUT DOWN)

DRAWING NUMBER:

18

SCALE:

NOT TO SCALE

DATE:

JULY 2009

TAPPING CONFIGURATIONS TYPICAL ARRANGEMENT

